

RAIL TITAN

MODULAR TIG-MIG-MAG WELDING AND CUTTING RAIL TRACTOR

Rail Titan is fully modular mechanized tractor that can be custom configured for TIG-MIG-MAG welding, oxy-fuel or plasma cutting and gouging applications on flat or curved plate, tube and pipe.

Linear torch oscillator produces straight, triangle, trapezoid and square weld paths.

Rail Titan can travel on hi-flex, semi-flexible, rigid or ring tracks that can be clamped to ferrous materials with magnetic units and to non-ferrous materials by means of vacuum track system incl. vacuum pump and vacuum units.

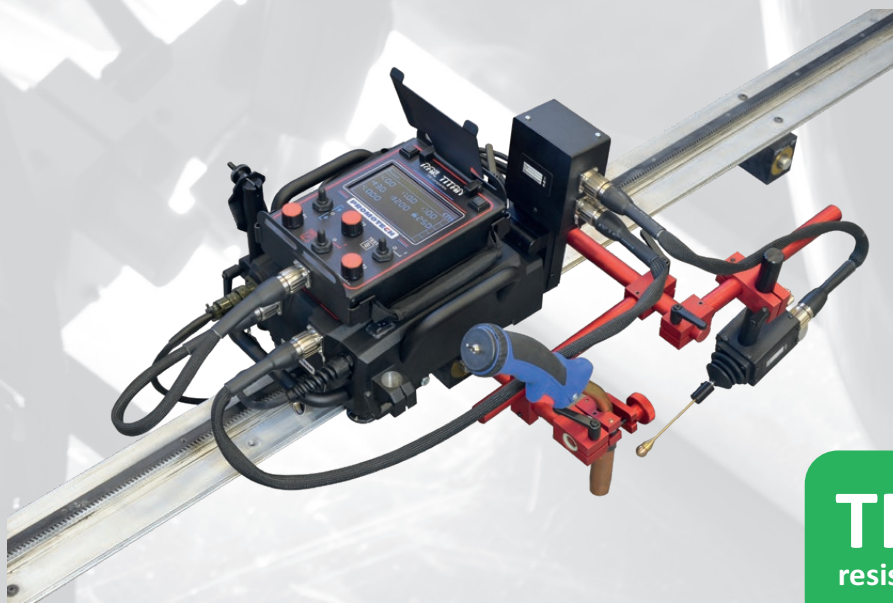

TIG
resistant

Primary features and benefits:

- Suitable for TIG welding (HF resistant)
- Robust design with die-cast aluminum housing
- Ergonomic remote control pendant with simple and easy to find control knobs makes adjustments possible without lifting of the operators welding hood
- Programmable path of stitch welds
- Suitable for variety of circumferential and irregular surface applications down to min. radius of 100 mm (4")
 - Ring tracks on diameters from 200 mm (8") OD up to 3 m (10 ft) OD
 - Hi-Flex tracks on diameters from 1500 mm (59") OD upwards
 - Semi-flexible tracks can be flexed to minimum radius of 5 m (16 ft) without permanent deformation
- Seam tracking enables active compensation of torch position vertically and horizontally with and without oscillation
- New type of signal sockets/plugs feature increased HF immunity and improved grip for easier tightening & loosening
- Suitable for all welding positions on both ferromagnetic and non-ferromagnetic materials thanks to rack and pinion drive and various tracks equipped with magnetic or vacuum units
- Rail Titan produces consistent high quality welds and cuts in a fraction of the time required by manual operations
- Wide input voltage range: 100-240V, 50-60Hz 1ph (single phase)



Linear oscillation with trapezoid, triangle, square and straight line paths



Ring tracks from 200 mm (8") OD up to 3 m (10 ft) OD



Hi Flex Track
min OD 1500 mm (5 ft)
min ID 3400 mm (11 ft)



Min. path convex radius for semi-flexible tracks is 5 m (16 ft)



Continuous welding



Stitch welding



Horizontal speed
0-250 cm/min



Vertical speed
0-250 cm/min

Rail Titan can work in all welding positions on both ferromagnetic and non-ferromagnetic materials by using rack and pinion drive and various tracks equipped with magnetic or vacuum units.

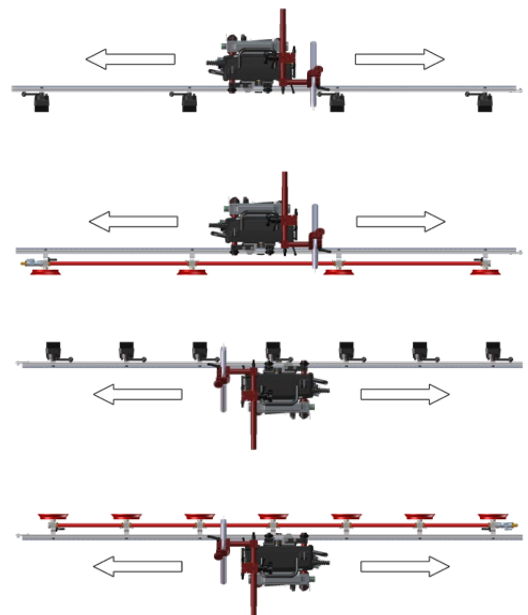
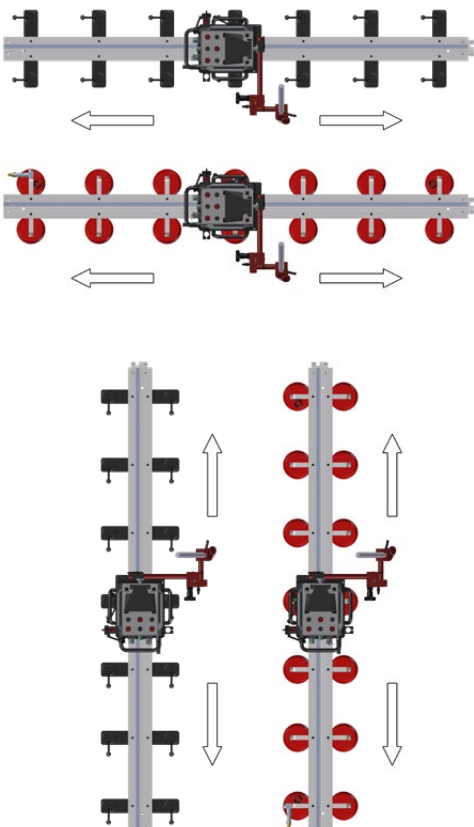
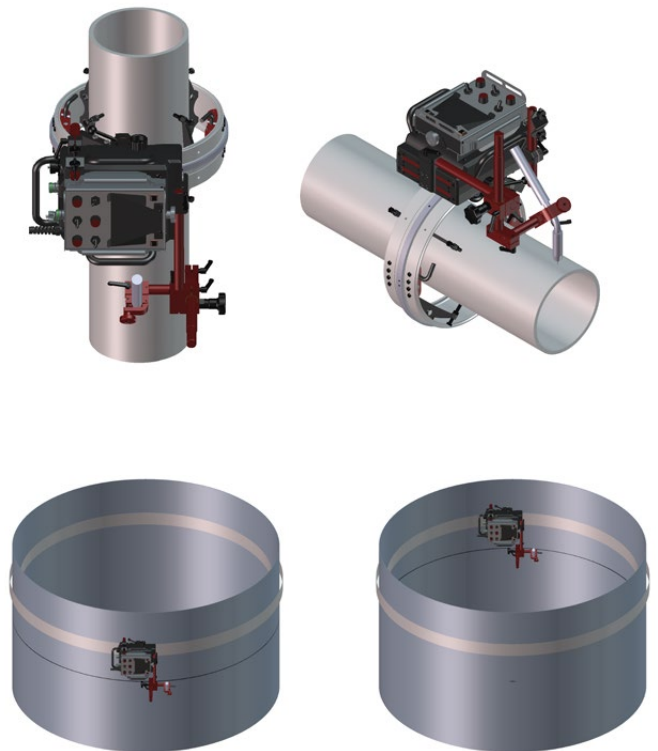

Weld paths

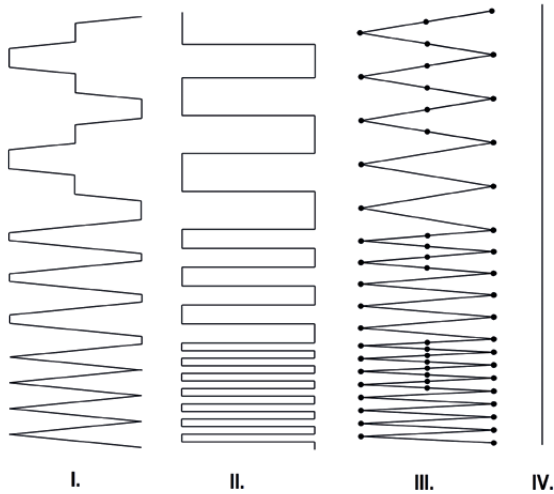

- I. Trapezoid The tractor travels continuously even during dwell mode. Weld path is determined by weave speed and dwell time at center and sides of the weld path.
- II. Square The tractor travels only during dwell and stops during oscillator cross travel. Only dwell time determines the weld path, and weave speed has no influence.
- III. Triangle The tractor travels only during weaving. Both the tractor and oscillation stop during dwell mode.
- IV. Straight The tractor travels continuously while oscillation is switched-off.



Single lever with lock to position Rail Titan to track



Silicone covers protect against dirt and spatter



New type of signal sockets and plugs

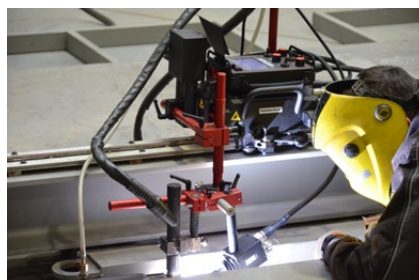

TIG welding of titanium plate



Seam tracking works with and without oscillation

Dimensions:

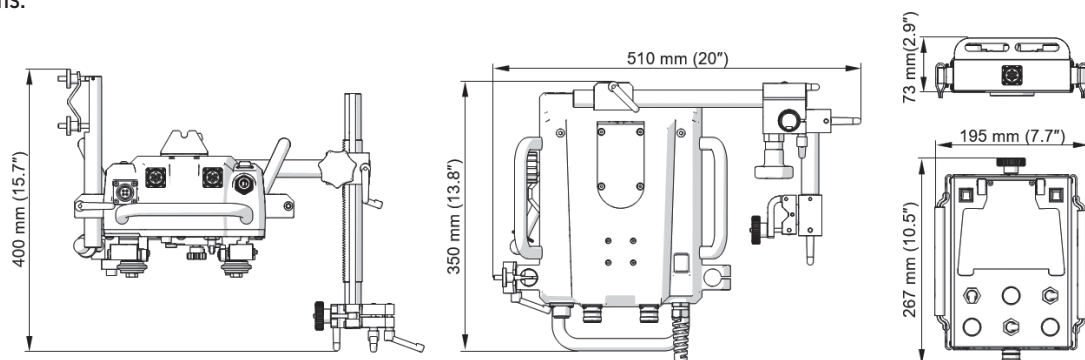

Standard accessories



Remote control pendant



Power cord 3 m (10 ft)
PWD-0466-18-00-00-0 (230 V CEE)
PWD-0466-16-00-00-0 (115 V USA)
PWD-0466-23-00-00-0 (115 V UK)



6.5 m (21 ft) arc ignition cable
KBL-0466-17-00-00-0



5 m (16.5 ft) remote control cable
3 m (10 ft) remote control cable
0.5 m (1.5 ft) remote control cable



300 mm (12") rod
WSP-0523-16-00-00-0



300 mm (12") rack
RAM-0523-17-00-00-0



Rackholder
ZSP-0475-62-00-00-0



Clamping block with levers
KST-0525-11-00-00-0



Short rod torch holder with fits-all clamp
UCW-0476-20-00-00-0



Cable anchor
UCW-0654-02-00-00-0



Contact block
ZDR-0523-76-00-00-0

Optional equipment

Configuration with seam tracking horizontally and vertically requires an optional seam tracking attachment and a motorized vertical slide



Seam tracking attachment
CZJ-0654-05-00-00-0

Rod for sensor tips
WSP-0523-07-01-13-0



Sensor tip (rod required)
ADT-0506-43-00-00-0



Sensor tip (rod required)
ADT-0506-40-00-00-0

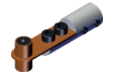

Sensor tip (rod required)
ADT-0506-41-00-00-0



Motorized vertical slide
OSK-0654-04-00-00-0

Rack adjustment tool
PKT-0341-13-00-00-0



Contact block for Hi-Flex track
ZDR-0673-08-00-00-0

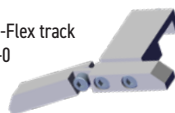

Transport Attachment
PEP-0523-93-00-00-0



Signal cable to connect Rail Titan
to OSC-8 pendulum oscillator
PWD-0654-10-00-00-0



Promotech offers a wide range of tracks suitable for variety of circumferential and irregular surface applications down to min. radius of 100 mm (4")

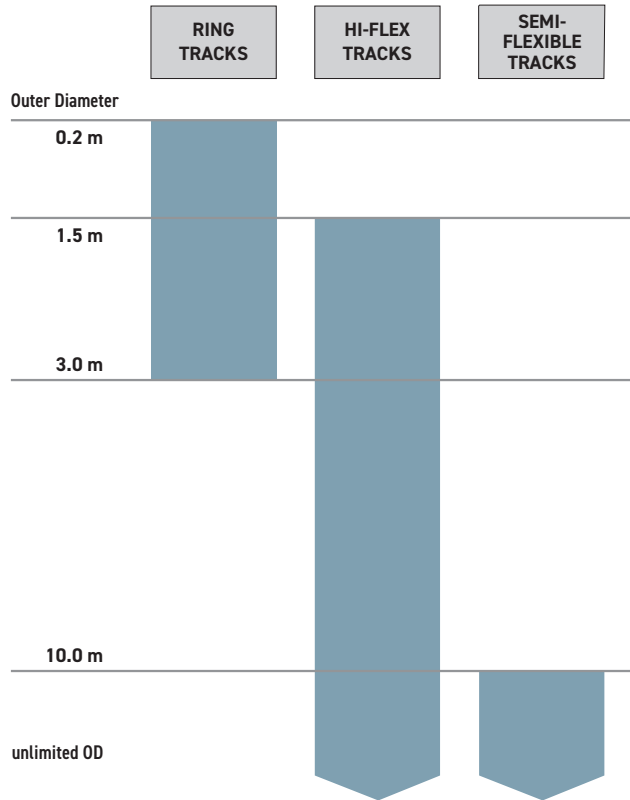

Ring tracks

For circumferential applications from 200 mm OD up to 3000 mm OD (from 8" to 10 ft.)

Ring tracks can be equipped with various supports depending on the customer's needs.



Support with bolts
WSP-0523-14-02-00-0

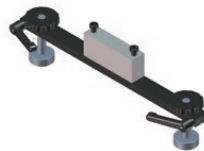

Support with magnets
WSP-0523-14-12-00-0



Support with plastic feet
WSP-0523-14-11-00-0

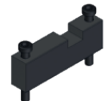

Bracket for ring track supports to expand pipe diameter range by 50 mm downwards
DYS-0523-14-14-00-0

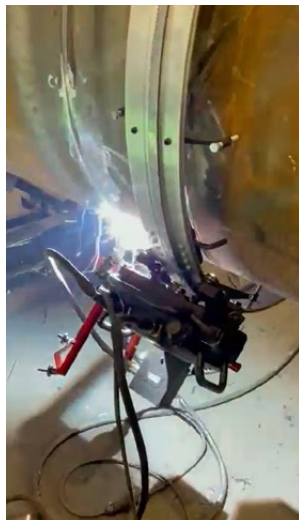
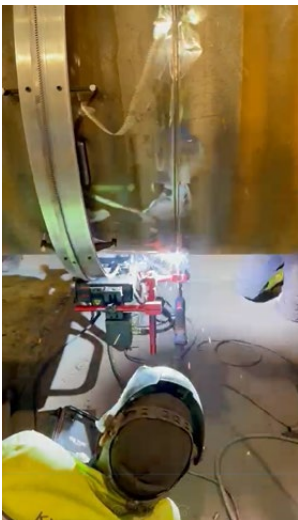

Hi-Flex tracks

For circumferential applications from 1500 mm (59") OD upwards

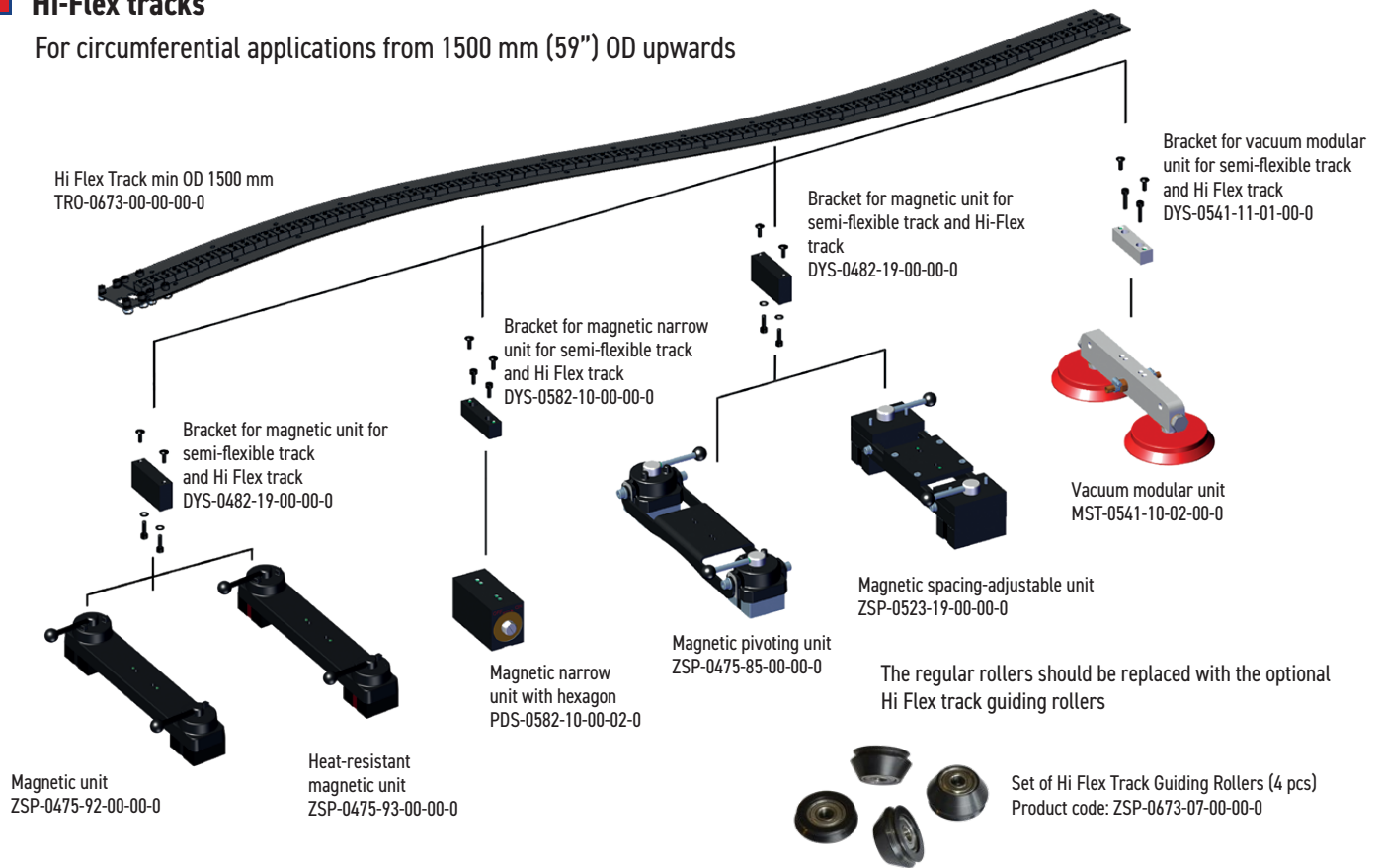

Semi-flexible tracks

For straight line and circumferential applications.

It can be flexed to minimum radius of 5 m (16 ft) without permanent deformation

Semi-flexible track length 2 m (6.5 ft).
Minimum 5 m (16 ft) curvature radius required
PRW-0482-15-05-00-0

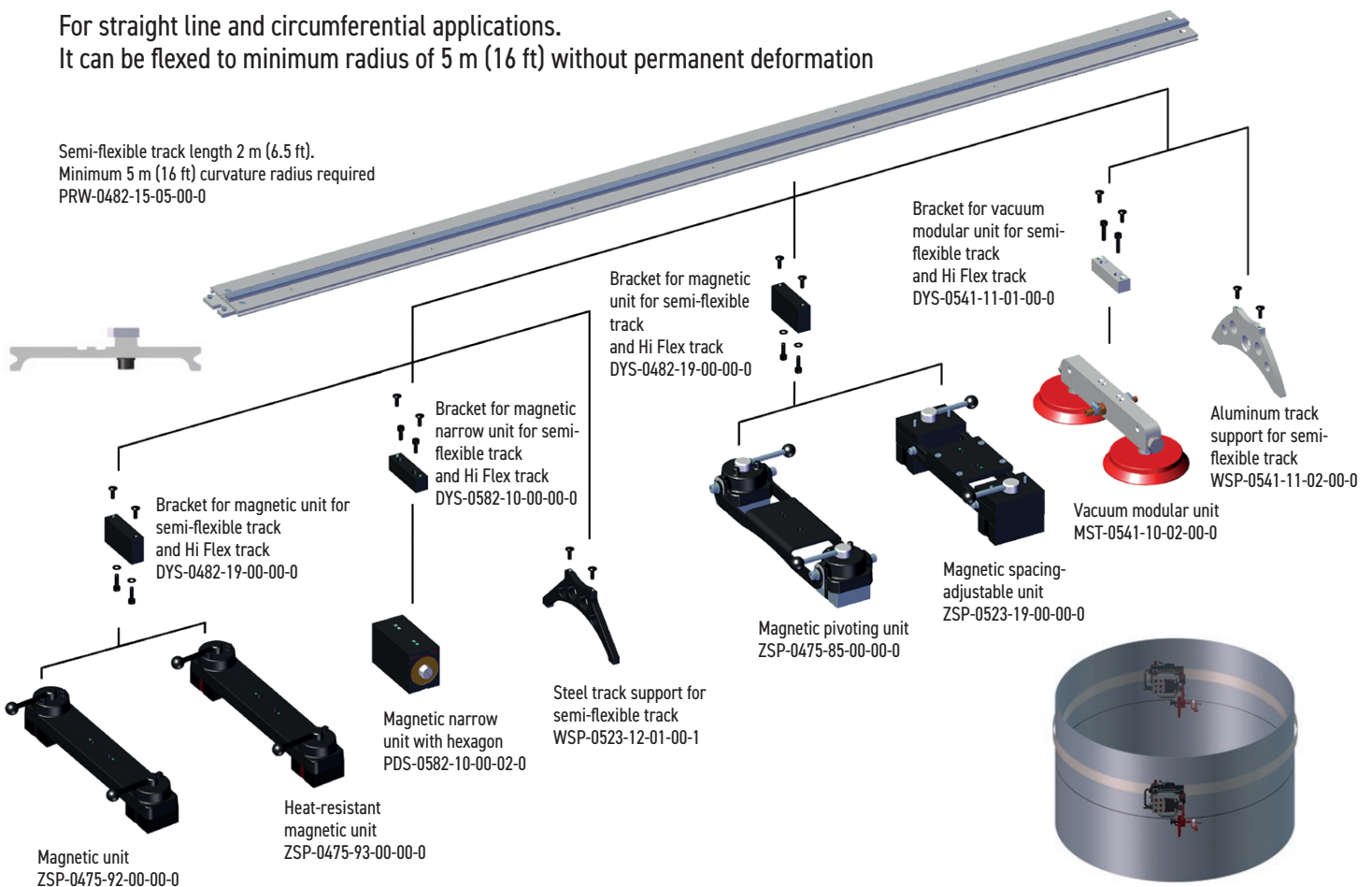

■ Rigid tracks

For straight line applications and for going beyond workpiece and continuous welding edge to edge

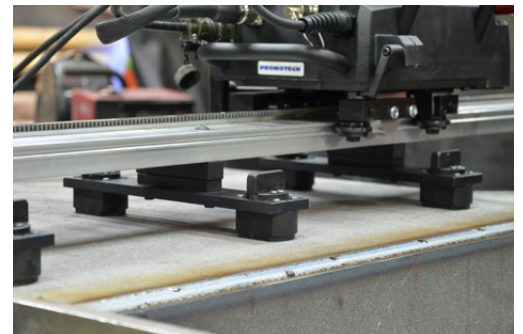
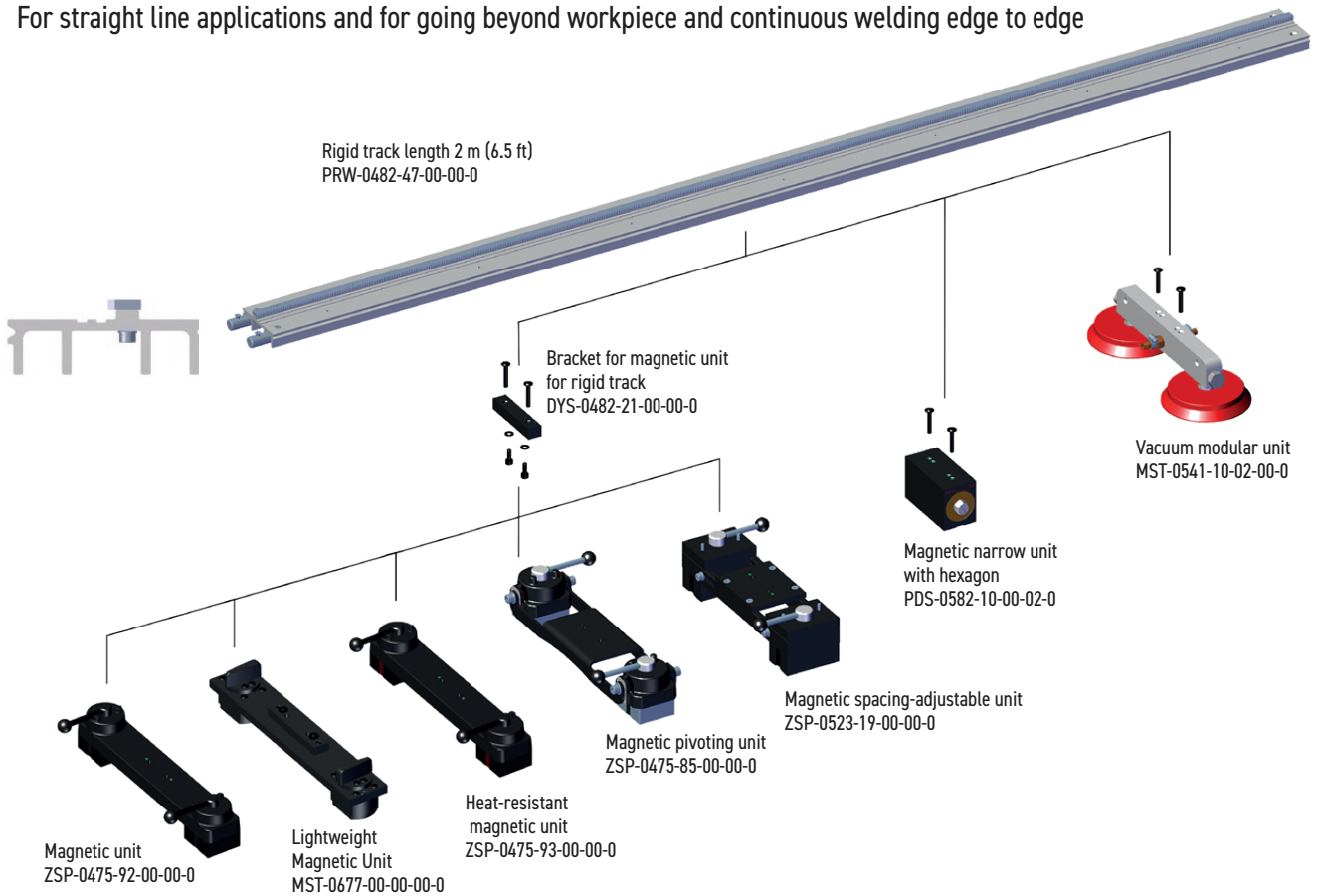

■ Vacuum tracks system

For non-ferrous applications

Promotech's vacuum fixing system provides firm grip of rail tracks on both ferromagnetic and non-ferromagnetic materials (aluminum or stainless steel constructions)

Portable vacuum pump with safety reservoir generates vacuum and supports up to 21 vacuum units

System can be configured as serial or parallel connection

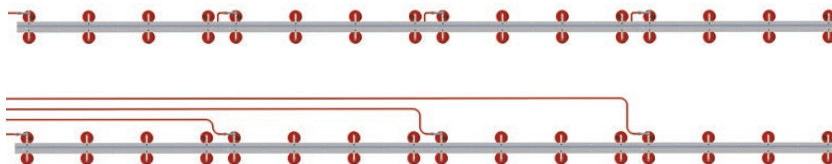

More information about Promotech's Vacuum System configurations and components is available at company website www.promotech.eu

RAIL TITAN Technical specification		
Voltage	1~100-240V, 50-60Hz	
Power	60 W	
Welding position (according to EN ISO 6947 and AWS/ASME)	Horizontal	PA/1F/1G PB/2F PC/2G PD/4F PE/4G
	Vertical	PF/3G PG/3F (contact your dealer) PG/3G
Fixing on pipes and round workpieces	Ring tracks (OD)	200 mm (8") – 3 m (10 ft)
	Hi-flex tracks (OD)	Minimum 1.5 m (5 ft)
	Hi-flex tracks (ID)	Minimum 3.4 m (11 ft)
	Semi-flex tracks (OD)	Minimum 10 m (32 ft)
Torch type	MIG/MAG, TIG, oxy-fuel, plasma	
MIG/MAG torch diameter	16–22 mm (0.63–0.87")	
Minimum workpiece thickness for magnetic clamping	5 mm (0.2")	
Horizontal pulling force	400 N	
Vertical pulling force	315 N	
Horizontal speed	0–250 cm/min (0–98 in/min)	
Vertical speed	0–250 cm/min (0–98 in/min)	
Oscillation type	Linear	
Weld path	Straight, triangle, trapezoid, square	
Oscillation width	0.1–11.8 cm (0.04–4.5")	
Oscillation speed	10–200 cm/min (5–78 in/min)	
Oscillation dwell time at center and on ends	0–5 s	
Maximum oscillator pulling force	100 N	
Weight (incl. standard accessories)	13 kg (29 lbs)	
Product code	WOZ-0654-10-20-00-0	



Standard shipping set:

- Rail Titan tractor
- Plastic box
- Remote control pendant
- 5 m (16.5 ft) remote control cable
- 3 m (10 ft) remote control cable
- 0.5 m (1.5 ft) remote control cable
- Power cord
- 6.5 m (21 ft) arc ignition cable
- 300 mm (12") rod
- 300 mm (12") rack with 180 mm (7") adjustment
- Rack holder
- Clamping block with levers
- Short rod torch holder with fits-all clamp
- Cable anchor
- Contact block
- 6 mm hex wrench
- Operator's manual

Applications:

- Trailer manufacturing
- Truck tanks
- Oil tanks
- Water storage tanks
- Pressure vessels
- Vessel overlay / hardfacing
- Bridge girders
- Structural steel
- Structural towers
- Panel welding
- Transformers
- Shipyards
- Any application demanding long continuous welds



American Welding Society

Supporting Company Member

Mitglied im DVS - Deutscher Verband für Schweißen und verwandte Verfahren e. V.



Shipping weight: 23 kg

Shipping dimensions (W x L x H): 515 mm x 830 mm x 340 mm

More information available at www.promotech.eu



PROMOTECH Sp. z o.o.
ul. Elewatorska 23/1, 15-620 BIAŁYSTOK, POLAND
tel. (+48 85) 678 34 05, fax (+48 85) 662 78 77
marketing@promotech.eu www.promotech.eu

Your local dealer:

