

PIPE(TUBE) CUTTER Of Best Technology

**S-Cutter**

# Manual

(S-100LT / S-150LT / S-200LT)



## Safety Precautions

Thank you for purchasing S-Cutter.

This is the instruction to prevent property damage, ensure the correct use and safety of the user.

Please read these instructions carefully before use.

WE BUILD TOMORROW  
**DCS ENG**





# CONTENTS

1. Precautions for the safe use	04
2. Please keep the following precautions	06
3. Check before use	08
4. S-□□□LT How to use the product	10
5. Quality Warranty	29



## Precautions for the safe use



- 01 Keep workshop clean.**  
Untidy workshop and work table may cause accidents.
- 02 Consider your work environment.**  
Do not let it wet.  
Do not use in damp or humid place.  
Install bright lighting in the work place.  
Do not use near flammable liquids or gases.
- 03 Protect from electric shock.**  
Avoid to touch grounded parts(i. e. Water pipes, heaters, ranges, refrigerators).  
Use it grounded.
- 04 Do not let outsiders access.**  
Do not let the outsiders in contact with tool or extension cord.  
Do not let visitors access to the work area.
- 05 Keep the product safe.**  
Cut off the power when the tool is not in use, and keep it where it is not accessible to outsiders .
- 06 Do not work in an overload condition.**  
Within the range of the specified output allows you to work more efficiently and securely.
- 07 Always use the proper tools.**  
Use the supplied standard accessories.  
Do not use tools outside of the scope of work or the intended use of the tool.
- 08 Dress properly.**  
Do not wear loose clothing or jewelry. You may be hurt by the moving parts of the tool.  
It is recommended to wear non-slip footwear for outdoor work.
- 09 Be sure to wear safety glasses and protective gloves.**  
Scattering tips can cause serious injury to the eyes, or injury, such as burns.
- 10 Do not abuse the cord.**  
Do not drag the product by grasping the wire.  
Do not pull the wire when disconnecting the plug.  
Protect wire from heat, oil and sharp edges.
- 11 Secure the workpiece.**  
Secure the workpiece by using a lock.

- 12 Focus on the job.**  
 Please note the fall, and cut piping pinch.
- 13 Manage the product carefully.**  
 keep the product clean and efficient for safe operation.  
 Manage with the proper lubricant, apply a corrosion inhibitor to prevent corrosion when not in use for a long time.  
 When replacing the management regulations and tools, comply with the instructions.  
 Check plugs and wires regularly and contact experts to repair the damage.  
 Check connection cables regularly and replace damaged parts.  
 Keep the control board dry and avoid getting oil or grease.
- 14 Remove power.**  
 When not in use, checked, or replaced, turn off the switch.  
 (Press the emergency stop switch before work.)
- 15 Please check before operation.**  
 Make sure that the tool(blade) has been tightened, blade direction and the direction of rotation.  
 Make sure that the piping is tightened.  
 Make sure the piping direction of rotation. (Check reverse rotation switch Forward(CW))  
 Make sure that the cutting, chamfered speed and rotational speed.
- 16 Be careful of operating the machine accidentally.**  
 Do not carry when the power is connected.  
 When turning on, make sure that the operation switch is off.
- 17 Supply of power**  
 Use connection cables with indications corresponding to their intended purposes.  
 Do not connect the currently used cable to other equipment.  
 Have a separate circuit breaker.
- 18 Be cautious all the time.**  
 Observe work process and process accordingly.  
 Do not use this product if the concentration is blurred,  
 Do not operate by force the cutting speed and rotational speed.
- 19 Make sure that there is no damage on the product.**  
 Make sure that safety devices or slightly damaged parts operate perfectly before reuse.  
 Make sure that the product is not stuck or damaged.  
 The perfect operation is guaranteed only if all the parts are perfectly assembled and adjusted.  
 Damaged safety devices or parts must be replaced or repaired in customer service center unless it was mentioned differently.
- 20 Caution!**  
 For your safety, use the parts and tools indicated on the manual or recommended by the manufacturer.  
 Use of other parts or additional tools that are not recommended on the manual and catalog may occur accidents.
- 21 Repair request to the experts**  
 The product supplied is matched to the corresponding safety regulations.  
 The repairs should be referred to a qualified technician and if not, there is a risk of accidents.



# Please keep the following precautions



- ▶ The instructions in this owner's manual contains information that is important to the safe use of this product.  
Not following these instructions can cause death, serious injury, and massive property damage.

- ▶ 'Warning' and 'Caution' are indicated and the meanings are as below.

Sign		Sign
	Warning	∴ If violated, serious injury or death may occur.
	Caution	∴ If violated, serious injury or death may occur. ∴ If violated, failure or performance degradation may occur.

- ▶ In order to prevent accidents that may occur when handling or using this product, precautions are recorded. As these warnings and cautions do not indicate all the cases that may occur, please pay attention when working or storing. Read carefully to avoid accidents.

- ▶ Special safety precautions  
'warning' or 'caution' are a caution: Injury or danger may occur under certain conditions.



## Warning

- **Make sure the power is connected to the ground.**  
Leakage current due to electric shock may occur if the product is not connected to the grounding.
- **Do not pour water or cutting fluid.**  
Due to water or other liquids on the electric motor, electric shock, or death may occur.  
Use cutting fluid until tools are slightly wet.
- **Do not use tools in wet conditions or rain.**  
Serious injury or death may occur by electric shock.
- **Avoid fingers, hands or clothes to touch the blade while operating.**  
When fingers, hands, or other body parts stuck in the machine, it may occur serious injury.
- **Avoid fingers, hands or other body parts to touch where pipe and roller meet while operating.**  
When fingers, hands, or other body parts stuck in the machine, it may occur serious injury.
- **Before supplying power to the product, be sure to turn off the operation switch.**  
Plugging in with the switch on may cause sudden rotation and occur serious injury.
- **Do not let any part of body to touch the compression device of product.**  
Serious injury may result.
- **Make sure to wear safety equipment.**  
Chips generated during the operation may scatter and cause serious eye injury.



## Caution

- **Be sure to apply our supplied product and cutting blades only for their intended uses.**  
Use only products certified for their quality (state-certified or higher-quality) in the event there is difficulty in procuring our products and accessories.  
If violated, performance degradation and serious injury may occur.
- **Do not leave the product rotated.**  
workers may result in bodily injury.
- **Place cutting chips safely.**  
When cutting chips meet flammable substances, it may cause fire and burns.
- **Wear gloves and long-sleeved clothes to wear.**  
Scattering chips can cause burns.
- **Use Extension cord as short as possible.**  
If too long or too thin, it may cause overload.
- **Operation before commissioning.**  
Check the machine before use for safety.



## Checked before use



### 1. Check the circuit breaker

Make sure that every power-operated product has a rated circuit breaker specified for the system installed.

Make sure that the ground wire is connected to the powered system.

### 2. Extension cord

When far away from the location of the power use an extension cord. Use the connecting cord appropriate length and thickness of the flow of current, in order not to interfere. If too long or too thin, it may cause overload and lower the power of the motor. Use it as short as possible.



**If the cord is damaged it must be replaced or repaired immediately.**

### 3. Check the power

Be sure to use the power listed on the nameplate.

### 4. Check the switch is off



**Unaware that the switch is turned on, the number of accidents due to a sudden rotation of the plug is inserted in the power being.**



# S-100LT / S-150LT / S-200LT

The most cost-effective orbital cutting machine!

The world best convenience and work speed !

Equipment capacity : 1/4 " ~ 8" (Pipe O.D 6mm ~ 220mm)

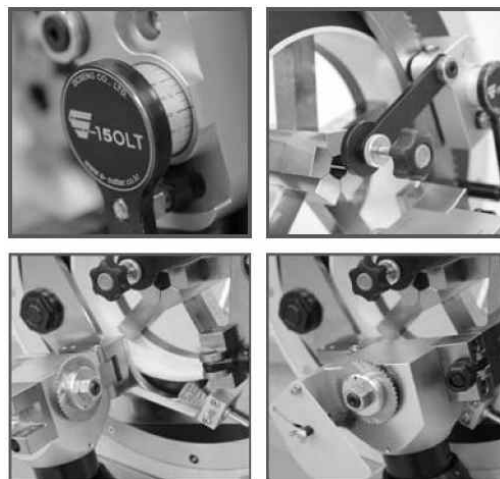



## How to use S-□□□LT

### How to use S-□□□LT

#### Before use

This User Manual is intended for S-100LT / 150LT / 200LT.

Please read about how to use manual provided by the headquarter or suppliers.

Users must be educated before use.

Make sure to remove the power exchanges when cutting or beveling.

Be sure to use consumables (such as cutting and beveling blades) for this equipment that are provided by use.

Make sure to connect the grounding, and confirm the voltage.

Make sure to wear protective equipment such as protective glasses before work.

Beware of burns when using chamfering tools which is extremely hot after operation.

Beware of burns by gearbox in case of prolonged use.

## INDEX

01. Name of each component and description of the control part
02. Installation of cutting blade and beveling blade
03. Setting of pipes
04. How to use cutting blade
05. How to use beveling blade
06. How to use clutch
07. Adjustment of cutting and rotating speeds
08. Repair and maintenance and check points
09. Product specifications

## 1. Names of parts and controls

- Names of parts

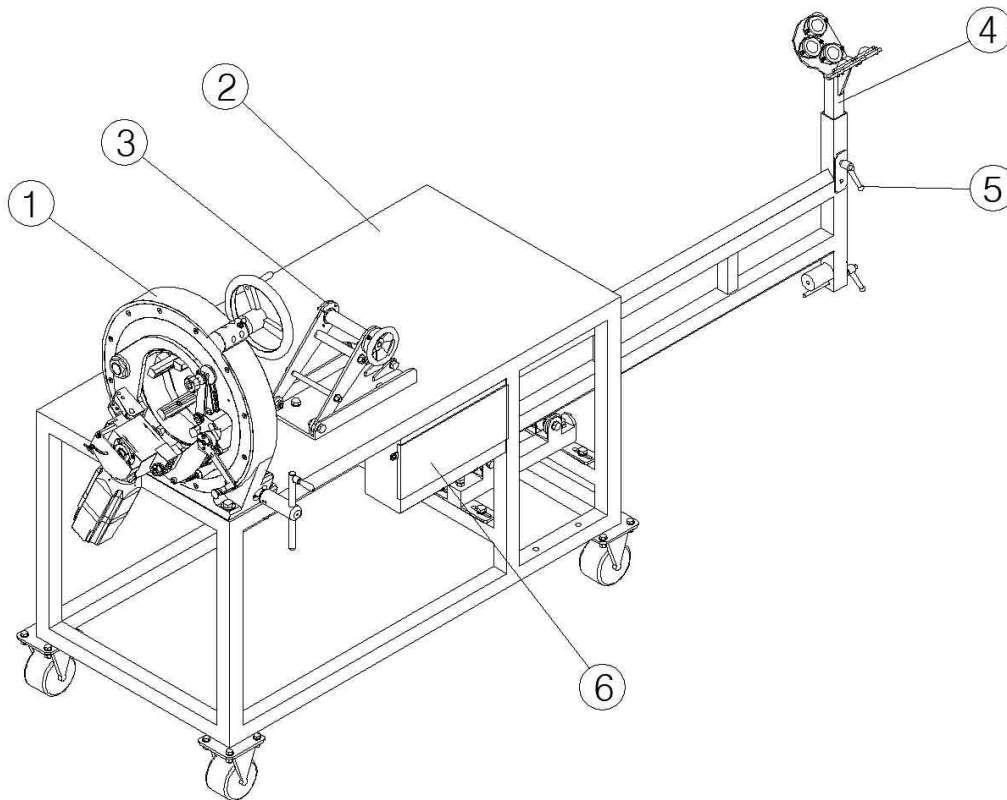

NO	Name	Function
1	Machine	Pipe cutting and beveling machine
2	S-□□□LT_MT (Machine table)	Work table
3	S-□□□LT_RS	Pipe feeder
4	S-□□□LT_VS (Travel type)	Long-pipe supports and feeding devices
5	Fixing lever	Pipe diameter-specific positioning bolt
6	Toolbox	Box for storing tools



● Function name

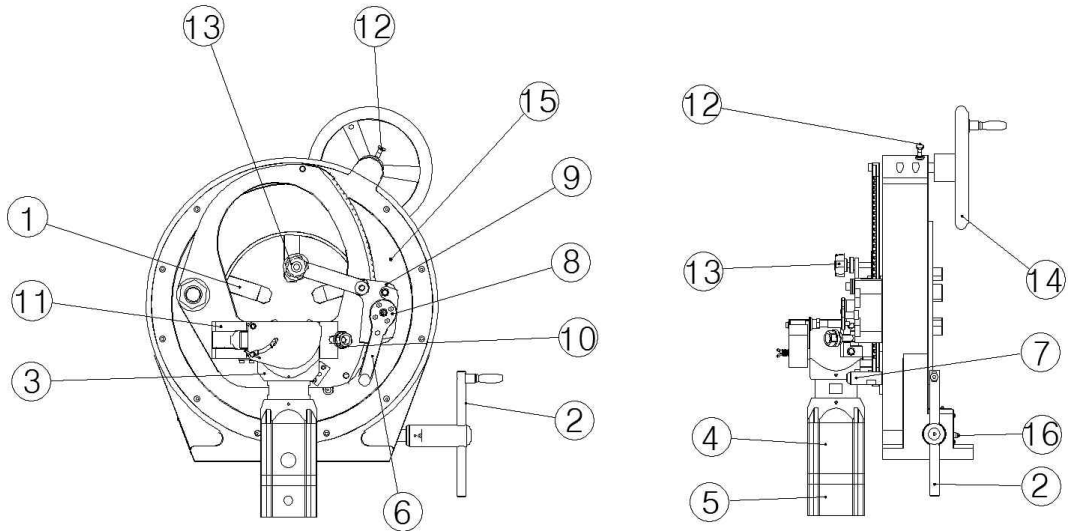

NO	Name	NO	Name
1	Vice jaw	9	Cutting handle gear box
2	Vice handle	10	Cutting head fixing nut
3	Cutting head	11	Folding bracket
4	Cutting motor	12	Rotating handle lock
5	Motor control part	13	Beveling stopper
6	Cutting handling	14	Rotating handle
7	Cutting handle fixing hole	15	Rotating oil nipple
8	Clutch	16	Vice oil nipple

● Names of controls

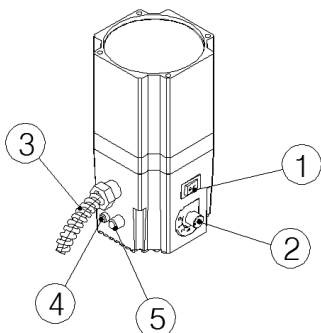

NO	Name	Function
1	Cutting switch	ON/OFF and Alarm reset
2	Cutting knob	Cutting speed control
3	Power cable	Power supply cable
4	LED lamp	Abnormal sign indication lamp
5	Fuse	5Ø-20mm, 250v-10A

## 2. Mounting of cutting blade and beveling blade

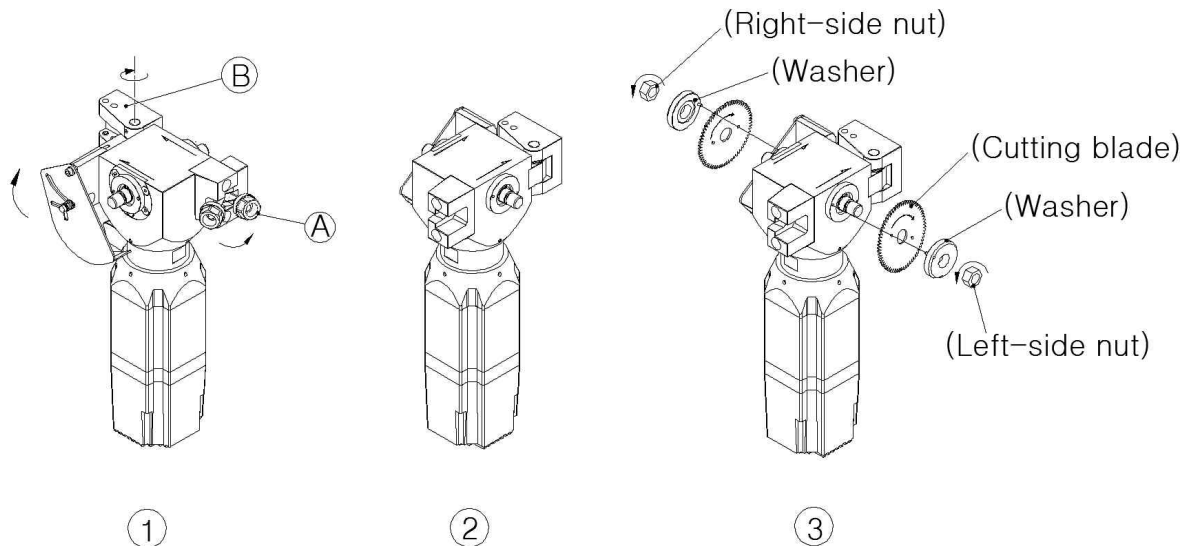

- ① To push the cutting head aside, loosen the cutting head fixing nut (A), move it in the arrow direction, hold the head with hand, and turn it in the folding bracket direction (B)
- ② Turn it until the head moves to about 90°, when a clicking sound is heard, so as to make sure that the cutting handle gear box remains firmly fixed.
- ③ Check for the arrow sign to which the cutting blade and cutting head turn and insert a cutting blade into the cutting shaft; then, match the fixing pin of the washer with the hole of the cutting shaft and tighten with the nut (firmly with a 22mm spanner).  
 Hold the cutting head and return it to its original position; then, tighten the cutting head fixing nut (A) using the 22mm spanner. (For S-100LT, a wrench bolt (6mm) is used.)



## 2-1. Fixation of the brush

- 1) The stainless brush is designed to achieve close contact with the cutting blade, as shown in the figure below, which is to be firmly fixed with a wing bolt (a) on the outside and a knurled bolt (b) on the inside. It is recommended to be used for improvement of the service life of a saw blade and cutting quality.

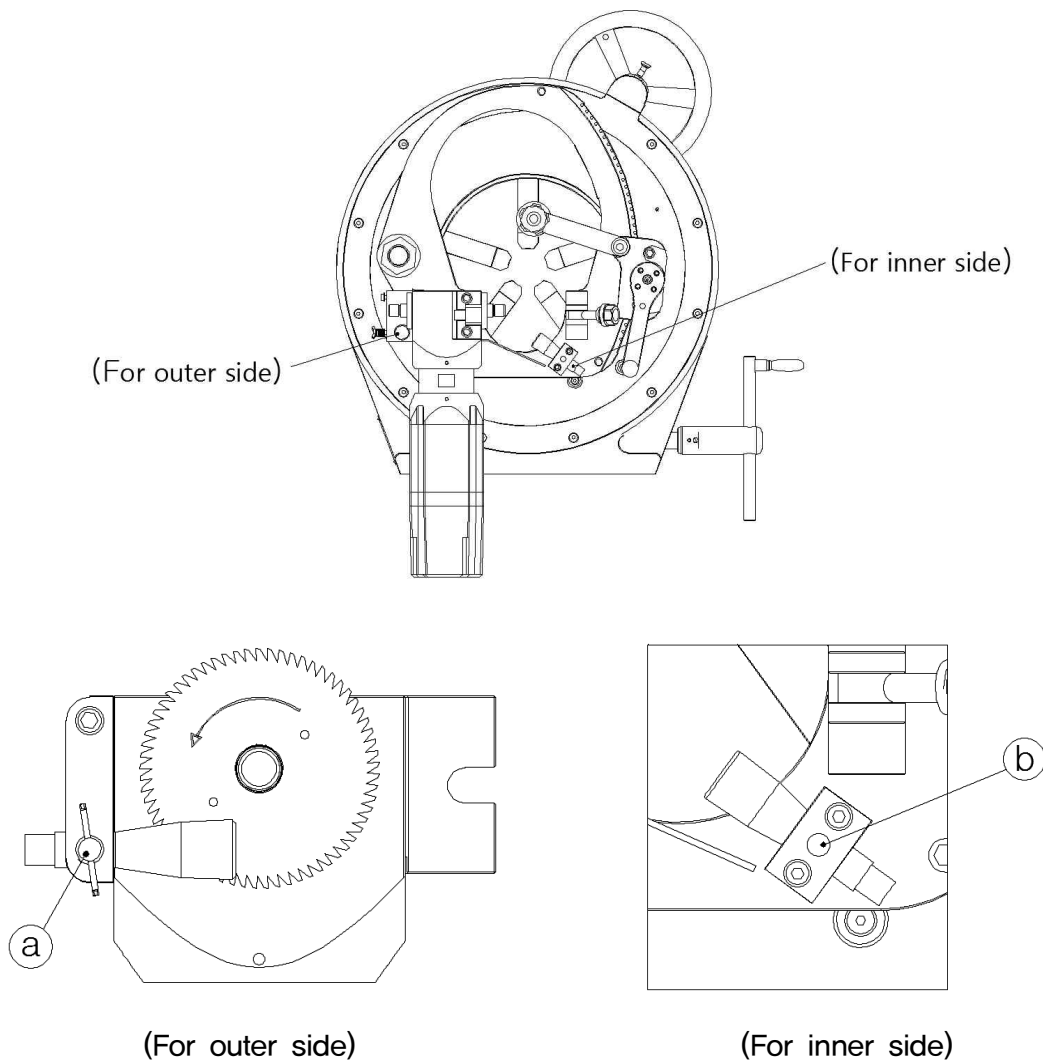

### 3. Setting of a pipe

#### 3-1. S-□□□LT\_VS : Adjustment of pipe' s height

- 1) For a long pipe, extend to its length the travel-type S-□□□LT\_VS mounted at the back of the table, as shown in the figure.
- 2) A standard table (S-□□□LT\_MT) is applicable to a maximum pipe length of 4m; if a pipe is 6m long, use one or more auxiliary supports as indicated in the figure.
- 3) A standard table (S-□□□LT\_MT) is designed for lightweight load; therefore, one or more auxiliary supports fabricated on the site should be used when it is applied to heavy pipes.

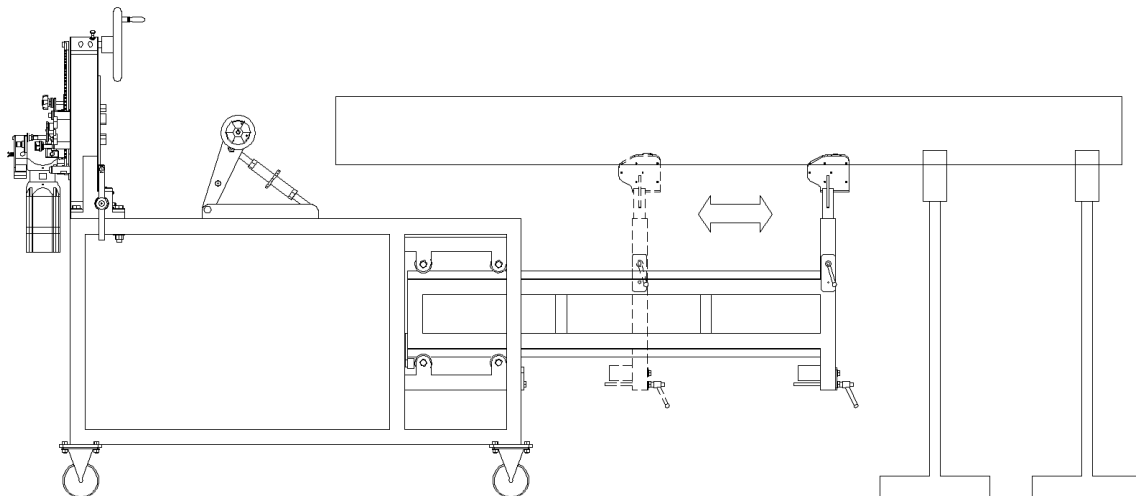

- 4) Choose a graduation marked on the post of the S-□□□LT\_VS, as shown in the figure, according to the size of a pipe to be processed.

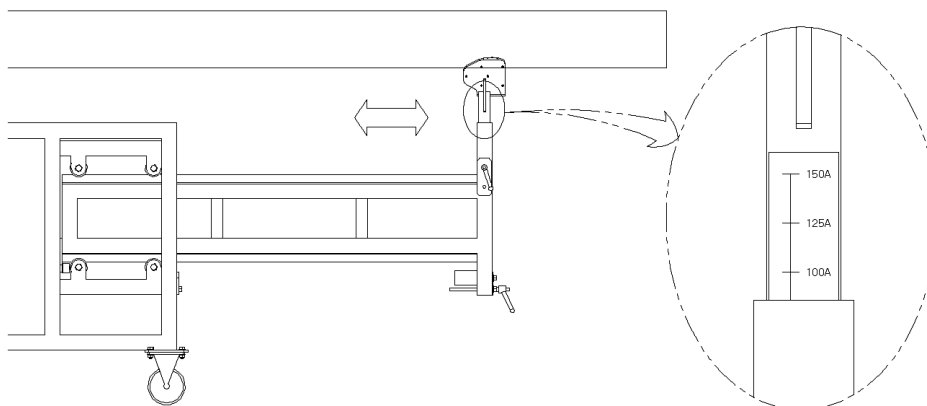



### 3-2. S-□□□LT\_RS : Pipe feeding device

- 1) S-□□□LT\_RS, a pipe feeder, is designed to fix a pipe to the machine, adjust its height (up and down) to bring the urethane into close contact with the bottom of the pipe and turn the handle to feed the pipe forward or backward to situate it to a desired cutting position.
- 2) The S-□□□LT\_RS can be adjusted to the outer diameter of a pipe; however, no additional manipulation is required when it is applied repeatedly to pipes of the same diameter.

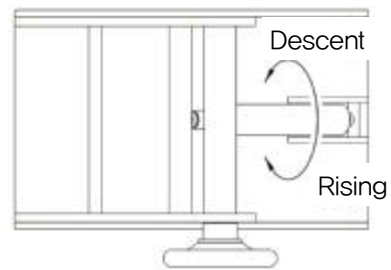
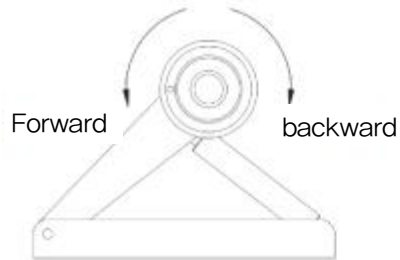



## 4. How to use cutting blade

### 4-1 Name of each component

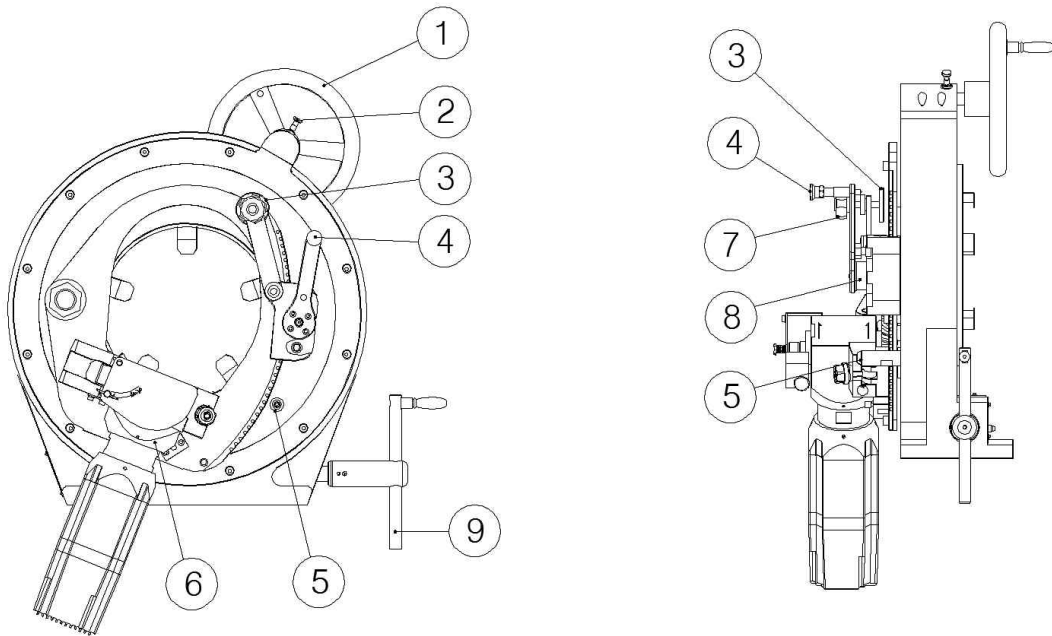

NO	Name	NO	Name
1	Rotating handle	6	Cutting head
2	Rotating handle lock	7	Beveling stopper bolt
3	Beveling stopper	8	Cutting handle clutch
4	Cutting handle	9	Vice handle
5	Cutting handle fixing hole		



#### 4-2 How to use beveling stopper

- 1) Rotate the beveling stopper bolt left or right until the stopper is aligned with the cutting position of the cutting or beveling blade, as shown in the figure. (Memory programmable)

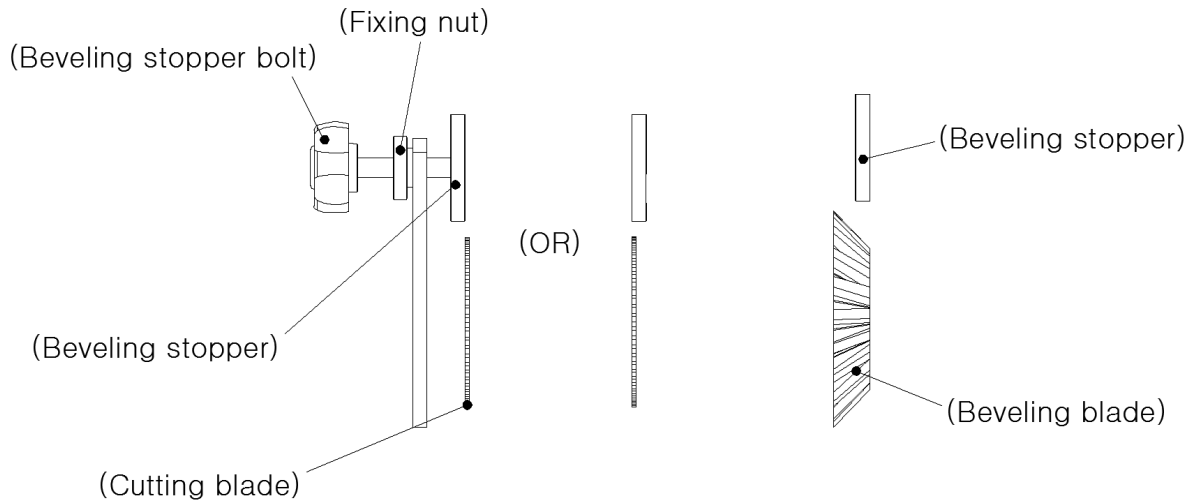

- 2) Align the side of the preset beveling stopper with the line that is marked on a pipe for its cutting position (memory function), as shown in the figure below; and, it must be restored to its original position so it is not interrupted by pipe when it is unused

(Home position of beveling stopper)

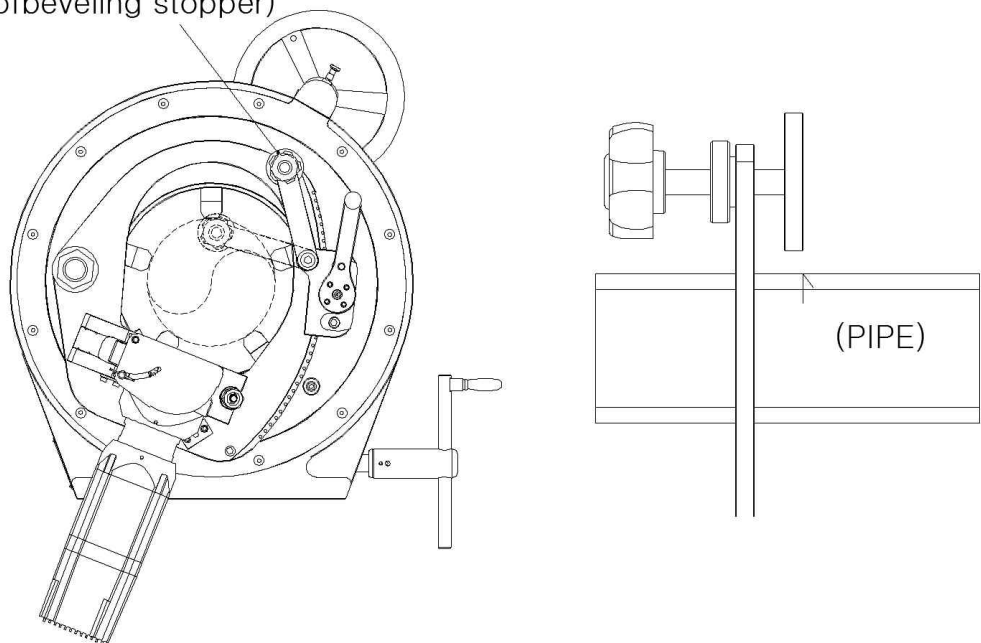

### 4-3 Selection of the position of the cutting blade

- 1) Turn the rotating handle lock slightly left or right to tighten the inner gear (in place), as shown in the figure, and fix a pipe temporarily until its section to be cut comes into contact with the blade.

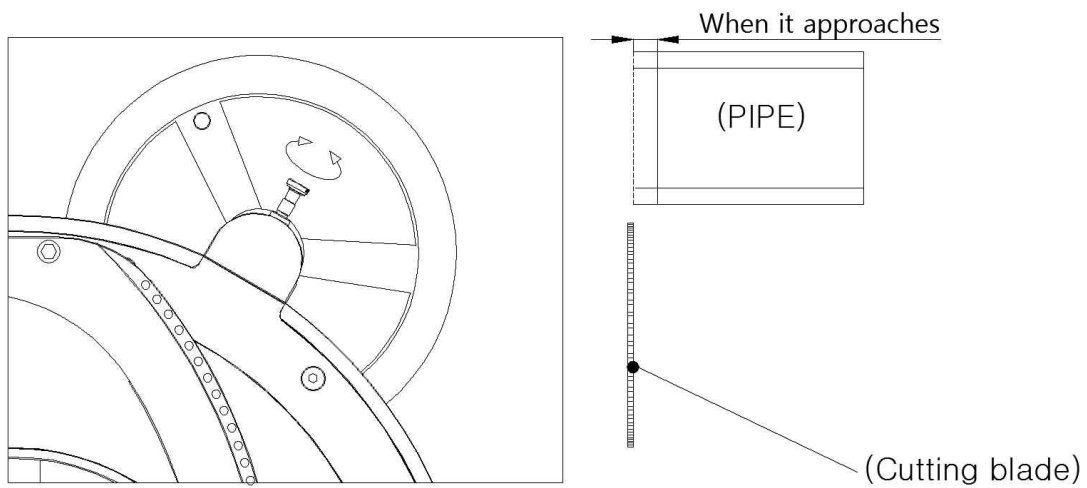

- 2) Turn and place the cutting handle in the cutting handle fixing hole, as shown in the left figure, and hold and move the cutting head (motor) up and down while pulling the cutting handle clutch, as shown in the right figure.

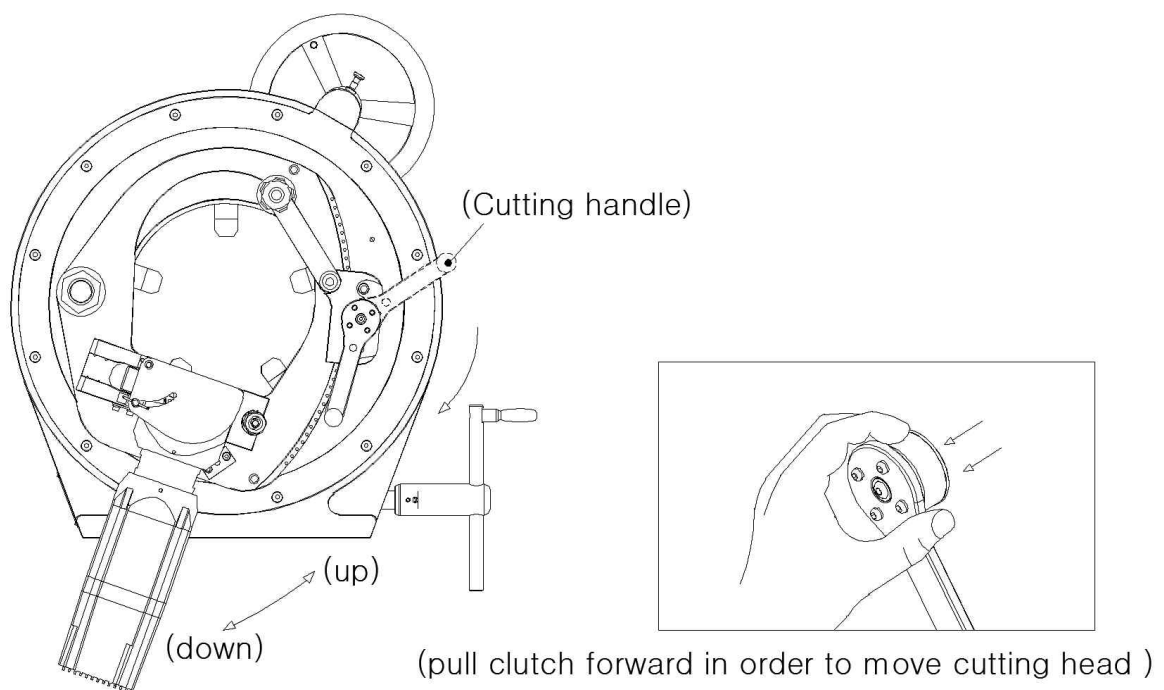



- 3) Move the cutting head (electric motor) up and down, as shown in the figure on the left, and adjust it to have the cutting blade maintain an appropriate depth value before the cutting handle clutch is released, as shown in the right-side figure, (when the head returns automatically).

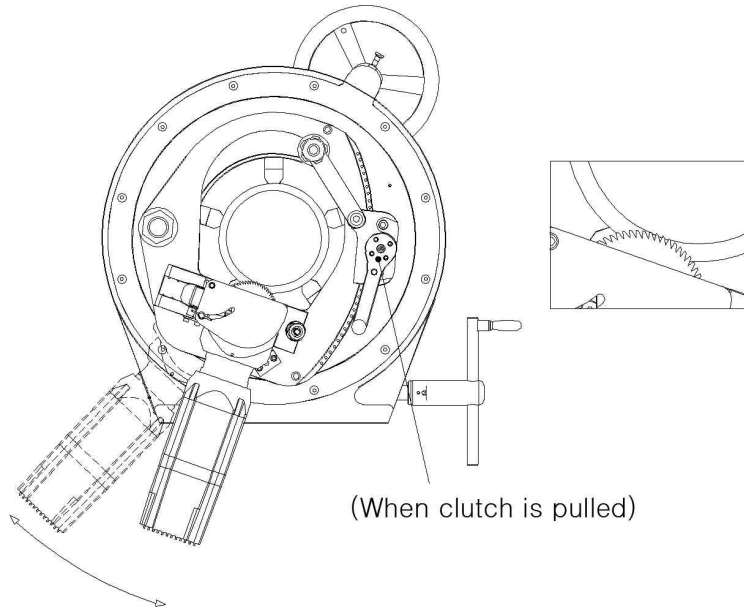

#### 4-4 How to cut

- 1) Separate the cutting handle from the fixing hole making sure that the cutting blade should have an adequate distance from the pipe.
- 2) Adjust the cutting position of the pipe (refer to Section 4.2) and turn the vice handle to fix it firmly.

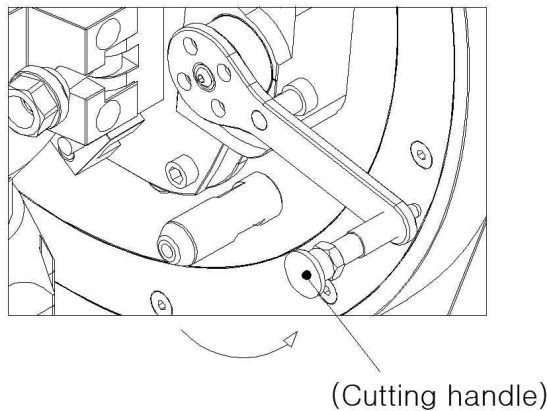

- 3) Turn on the power switch mounted on the cutting head (motor) and rotate the cutting handle slowly into the cutting handle fixing hole (downward) so as for the cutting blade to penetrate the pipe, as shown in the right figure. (Placing the cutting handle in its fixing hole allows the cutting blade to come to the cutting position, as indicated in Section 4.3.)

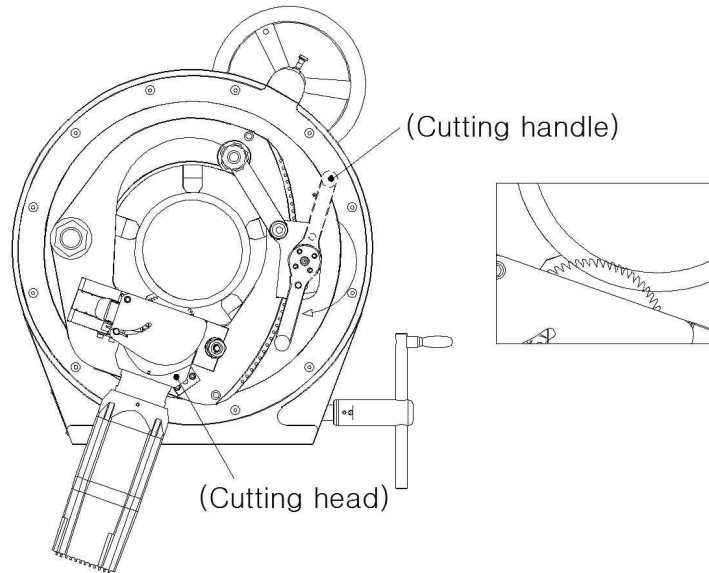

- 4) Move the rotating handle lock upward to release it, as shown in the figure below, and then turn the rotating handle in the direction as shown in the figure on the right to begin with the cutting work (be noted that the rotating handle turns only to one direction).
  - 5) Pay much attention not to let the cut portion of the pipe fall down when the cutting is over
  - 6) Separate the cutting handle from the fixing hole after the work is finished so that the cutting blade keeps distance adequately from the cut section of the pipe.
- \* Note) When the cutting handle enters (at the beginning of cutting work/subsequent penetrating work), repeat the penetration cycle several times (repeated cycles of “enter–retract–enter” ).

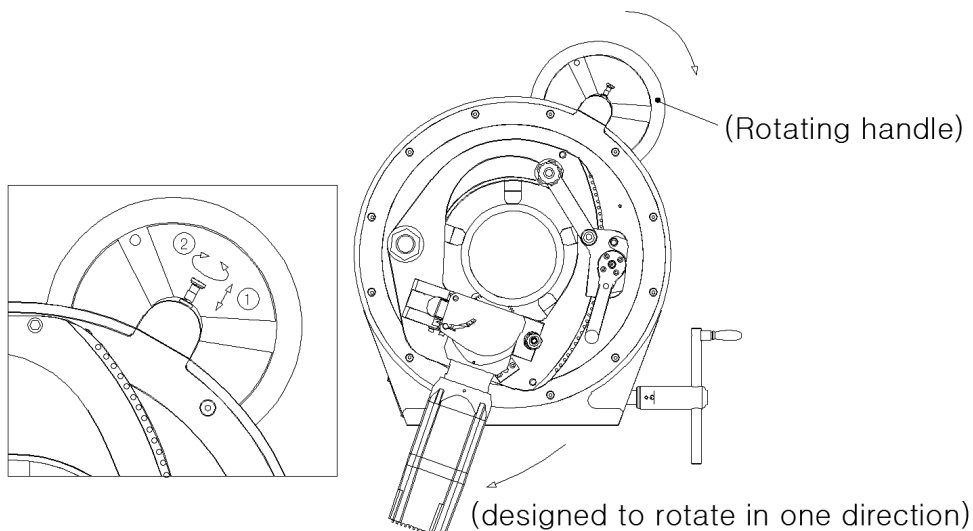



## 5. How to beveling blade

### 5-1 Name of each component

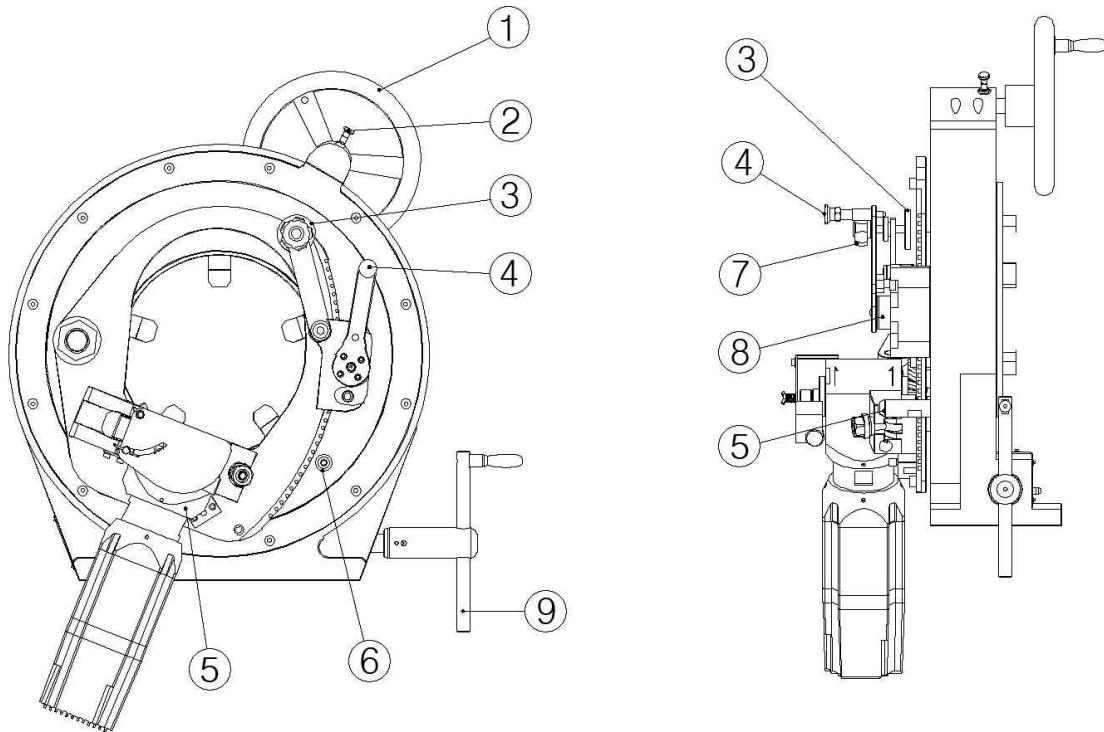

NO	Name	NO	Name
1	Rotating handle	6	Cutting handle fixing hole
2	Rotating handle lock	7	Beveling stopper bolt
3	Beveling stopper	8	Cutting handle clutch
4	Cutting handle	9	Vice handle
5	Cutting head		

## 5-2 How to use beveling stopper

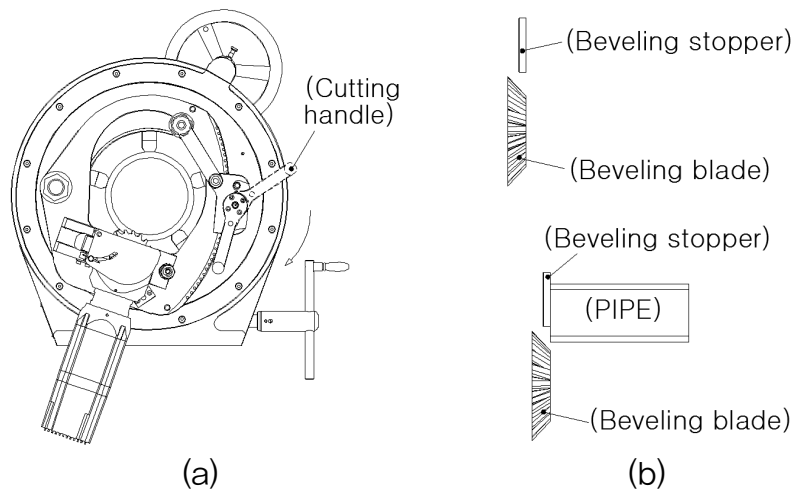

- 1) Turn the cutting handle downward, as shown in the figure (a) above, and place it in the fixing hole
- 2) Turn the beveling stopper bolt left and right while adjusting a pipe to allow the part to be beveled to situate itself at a given section of the beveling blade, as shown in the figure (b) above. (Refer to Section 4.3 for decision of the desired location of the beveling blade.)
- 3) Separate the cutting handle from the fixing hole and return it upwards when the setting of a desired position is finished.
  - \* Note) Even use of the inclined cutting blade will lengthen its service life.
- 4) Bring the pipe to close contact with the beveling stopper; then, fix the pipe firmly and try doing the beveling work.
- 5) Fine tune the beveling stopper according to the result of the temporary beveling work, as shown in the figure, before the beveling stopper is returned to its home position and the work proceeds.
  - \* Note) Fine tune it several times until a desired beveling result is obtained.

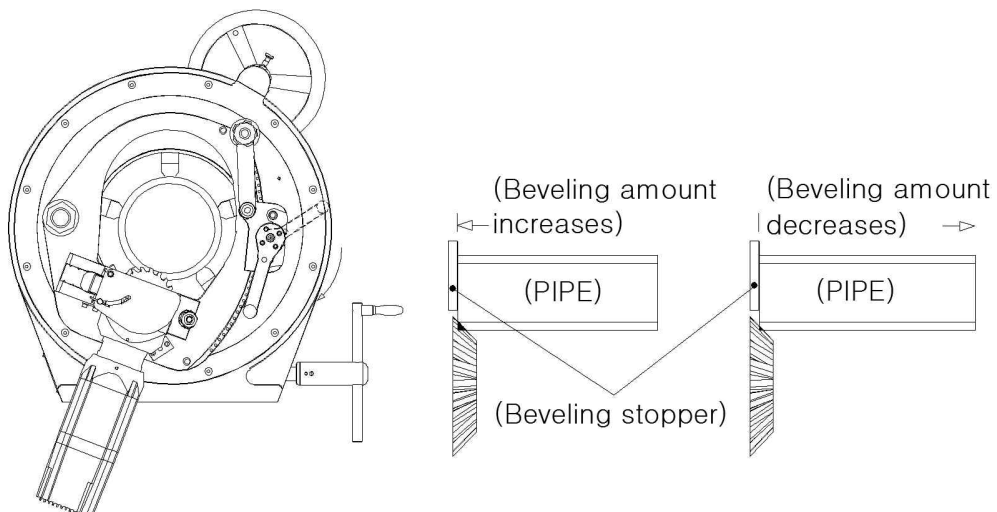



### 5-3 How to perform beveling

1) Start beveling work in reference to Section 4.4: “How to Cut.”

\* Note: Make several preliminary attempts before the cutting handle enters and does the beveling work (by repeating a cycle of “enter–retract–enter” ).

\* Note: Making good use of the beveling stopper achieves effective repetition of work and uniform beveling quality.

## 6. How to use cutting handle clutch

### 6-1 Name of each component

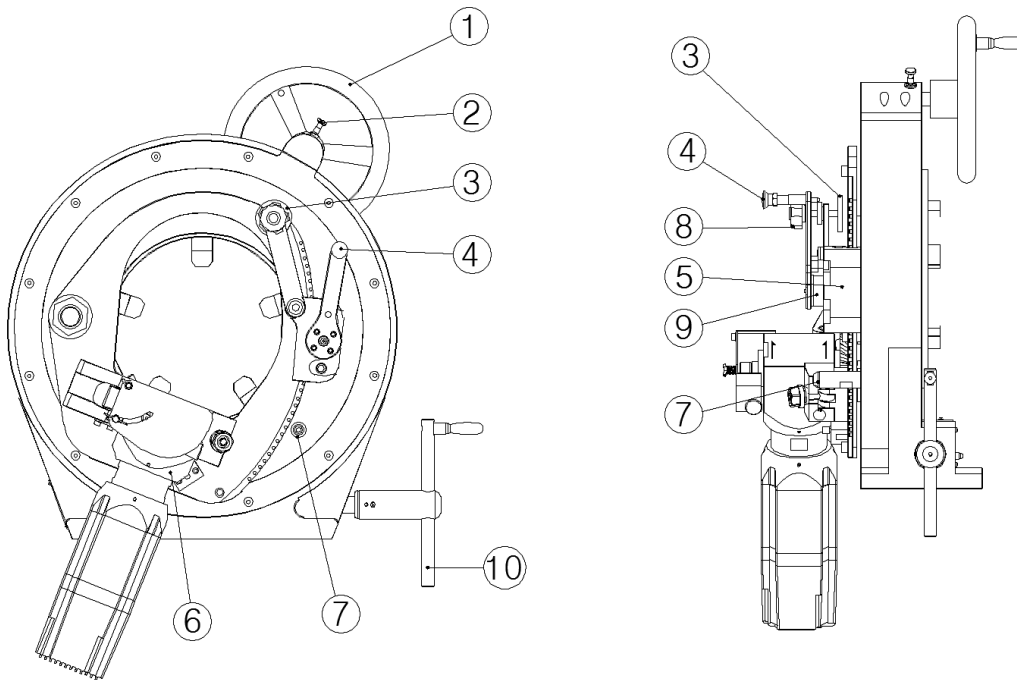

NO	Name	NO	Name
1	Rotating handle	6	Cutting head
2	Rotating handle lock	7	Cutting handle fixing hole
3	Beveling stopper	8	Beveling stopper bolt
4	Cutting handle	9	Cutting handle clutch
5	Cutting handle gear box	10	Vice handle



## 6-2 How to use cutting handle clutch

- 1) The cutting handle clutch is used when the cutting (beveling) blade mounted on the cutting head needs fine tuning (entry or retraction).
- 2) When the cutting handle is settled in its fixing hole, the minute graduation marked on the clutch matches the reference graduation of the cutting handle gear box.

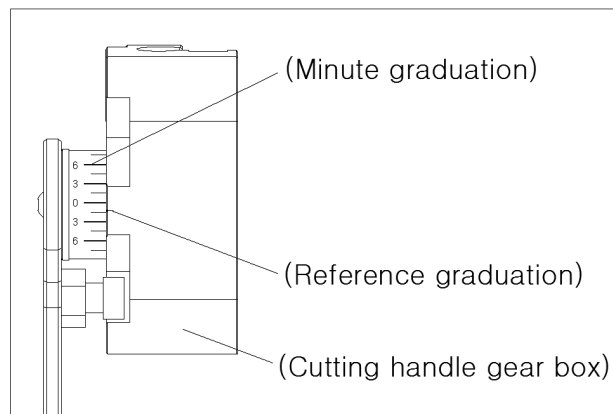

- 3) Separate the cutting handle from the fixing hole and pull and turn the clutch left and right to fine tune the cutting blade, as shown in the figure (A). (Each graduation marked on the clutch reads 1.5mm.)

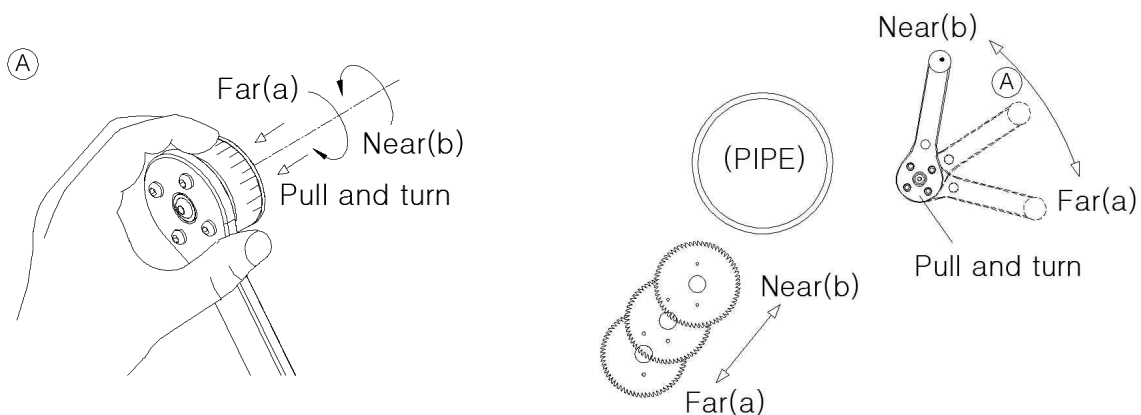



## 7. Adjustment of cutting and rotating speeds

### 1) How to adjust cutting speed

Step	Work	Pipes used
0	Special mode	Aluminum, PVC, titanium, inconel, duplex, etc
1	Cutting	Stainless steel, carbon steel, etc
2		
3		
4	Beveling	All kinds of pipes made of materials mentioned above
5		

### 2) Rotating speed adjustment

The rotating handle is designed to rotate in the counter-clockwise direction at a speed appropriate to the thickness of a pipe (impossible to rotate in reverse).

\* Note: The cutting head rotates in the clockwise direction.

## 8. Maintenance and inspection

### ● When maintaining or inspecting, please remove the power plug

#### A. Inspection of the screw device for each part.

Regularly check that the device on each part where the screw is loosened. If screws are loose, tighten firmly. It is very dangerous to leave them loose.

#### B. Check of the pipe-fixing vice

As it is important to fix the pipe, check regularly and apply suitable lubricants(WD-40).

When working with Vice with a problem, serious injury occurred, and the product of its own life may be shortened.

#### C. Check the handling of the major operation part

Supply grease oil regularly on the sides of rotating gearbox and main gearbox.

▶ Rotating gearbox inside gears can wear out easily and must be replaced regularly.

Check and supplement indicated (Synthetic gasoline engine oil) in the upper surface of cutting gearbox.

Check if you are experiencing a strange noise when idling.

Check if the gearbox is leaking

#### D. Sounding of the alarm and replacement of a fuse

When an alarm sounds during work due to an overload condition or an electric shock, the LED lamp begins to flash, when resetting can only be resumed several seconds after the power switch is kept OFF. (Please check LED if it is turned off.)

Replace the fuse (10A, 5 $\phi$  × 20mm) mounted on the side of the motor.

#### E. When the product does not operate normally

It is very dangerous for consumers to find or repair the fault area – Contact nearest A/S center or agencies.

## 9. S-□□□LT Product Specifications

### ● Machine Specifications

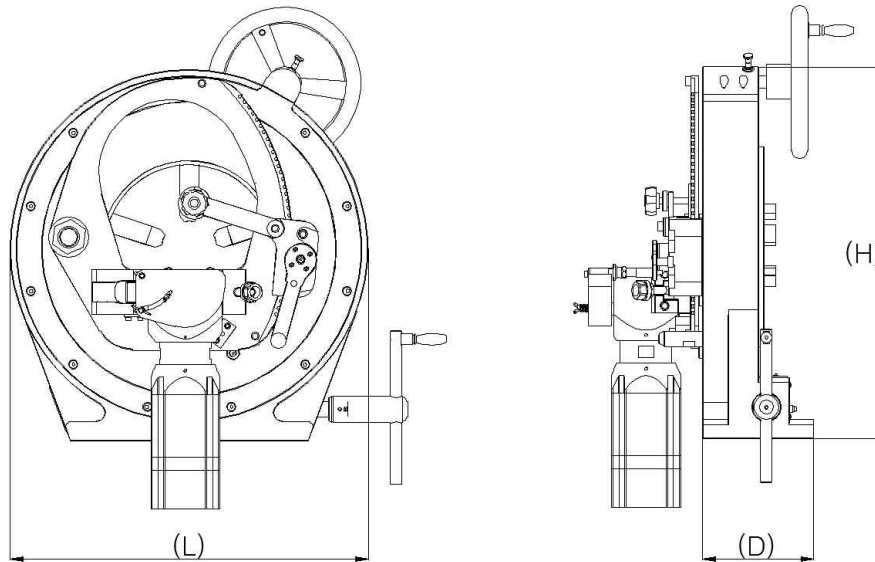

	Item	Unit	Spec	
<b>S-100LT</b>	Cutting / Beveling Capacity	Min./Max. aperture	mm(inch)	13(1/4) / 120(4)
		Min./Max. Thickness	mm	0,2 / 8,2
		Beveling Angle	°	30/32/35/37,5/45
	Machine Specification	Size(D×L×H)	mm	143 x 366 x 383
		Weight	kg	47
<b>S-150LT</b>	Cutting / Beveling Capacity	Min./Max. aperture	mm(inch)	20(1/2) / 170(6)
		Min./Max. Thickness	mm	0,2 / 8,2
		Beveling Angle	°	30/32/35/37,5/45
	Machine Specification	Size(D×L×H)	mm	145 x 466 x 483
		Weight	kg	66
<b>S-200LT</b>	Cutting / Beveling Capacity	Min./Max. aperture	mm(inch)	60(2) / 220(8)
		Min./Max. Thickness	mm	0,2 / 8,2
		Beveling Angle	°	30/32/35/37,5/45
	Machine Specification	Size(D×L×H)	mm	145 x 525 x 542
		Weight	kg	77

- The minimum cutting thickness is based on 10A.
- The design and specifications described herein are valid as of October 2016.
- This product is subject to change without prior notice for the purpose of improving the performance of the product.
- Be sure to read carefully and get familiar with the instructions and precautions contained in this User Manual and marked on the product before you use the machine.
- Installation of an auxiliary vice jaw device (such as collet) to an S-□□□LT product enables you to process pipes having a thickness of more than 1.0mm.



● Motor Specification

Items	Unit	Cutting motor
Rated output	W	1000
Rated voltage	V	AC220/60Hz
Rated current	A	5.0
Operating environment	—	-20°C~40°C / 20~80%RH

● Standard Accessory

Integrated tool box : Standard accessory

● Option Accessory

S-□□□LT\_RS : Pipe transfer device

S-□□□LT\_VS : Pipe Stands

S-□□□LT\_MT : Basic machine table.



# Quality Warranty



It guarantees as below.

1. This product have passed the thorough quality inspection of ECSENG CO.,LTD.
2. When the product is damaged in a normal operation, the product will be repaired free of charge for one year in the purchasing place or service center in accordance with the contents of this certificate.
3. But, the erturn delivery fee will be charged. Malfunction of the product after the warranty period completed or occurred by customer's carelessness, can be repaired or replaced at a minimum cost.
4. However, malfunction due to change of use, abnormal wear, using patrs from other companies, or repair in other A/S center may not be covered by the warranty certificate.
5. Repair cost will be charged in these cases;
  - Damage caused by the negligence of the user
  - Failure caused by not following precautions outlined in this product
  - Failure due to unreasonable repair and renovation.
6. The warranty certificate must be accompanys when repairing.
7. This certificate is not reissued.

Product Name		Warranty Period	One year from purchase date		
Model No.		Purchase Date	20	/	/ /
Serial Number		Date of Manufacture	20	/	/ /
Customer Address		Name			
		Phone Number			
Dealer Address (Shop Name)		Name			

※ Fill out the when selling products.

**DCSENG** DCSENG CO., LTD.  
<http://www.dcseng.co.kr>

Address : 12, Jukjeon-ri, Hyeondo-myeon, Cheongju-si, Chungbuk, Korea  
 TEL : +82-43-256-0945 / Fax : +82-43-256-0946  
 e-mail : dcs@dcseng.co.kr

PIPE(TUBE) CUTTER Of Best Technology



DCSENG CO., LTD.

12, Jukjeon-ri, Hyeondo-myeon, Cheongju-si, Chungbuk, Korea

T +82-43-256-0945 F +82-43-256-0946

W [www.dcseng.co.kr](http://www.dcseng.co.kr) [www.s-cutter.co.kr](http://www.s-cutter.co.kr)